

Lab Report XRF 98

S8 TIGER 1 K

Reliable analysis of very low levels of sulphur in petroleum products according to ASTM D 2622-08

Introduction

Sulphur in automotive fuels has been a source of toxic air pollutants like sulphur dioxide and sulphates. The international legislation enforces today very low residual sulphur concentrations in fuels, like the actual limit of 30 ppm for diesel in the US. The EU directive 2003/17/EC regulates the maximum allowed level in the European Union to 10 ppm. Future regulations may drive these limits down even further.

Wavelength-dispersive X-ray fluorescence (WDXRF) analysis is today the method of choice for accurately and precisely analyzing low sulphur concentrations in petroleum products. WDXRF instrumentation is easily integrated into industrial environments such as refineries and laboratories due to its simple sample preparation, reliability, ease-of-use and accurate analytical results.

The S8 TIGER 1 K brings additional advantages for the analysis of low sulphur in petroleum products and is easily satisfying the requirements of ASTM D 2622-08. This report will outline the analytical performance of the S8 TIGER and describe the specific benefits for this analytical task.

Instrument

The S8 TIGER 1 K is the perfect solution for performing elemental analysis for the hydrocarbon processing industry. Traces of sulphur can be analyzed with very low detection limits and best precision due to the optimized beam path. High sensitivity for sulphur is achieved with the close coupling between X-ray tube and sample and the curved germanium analyzer crystal. Without the need for an additional external cooling device and no need of compressed air the installation and reliable operation is guaranteed for the S8 TIGER 1K.

The S8 TIGER 1 K is optimized for highest instrument uptime, lowest cost of ownership and ultimate reliability. The unique SampleCare™ feature of the S8 TIGER 1 K outperforms other conventional WDXRF due to its complete protection of the spectrometer chamber and its components in case of sample spillage. The unique vacuum seal separates the sample and spectrometer chamber and ensures complete reliability for petroleum users. It locks out fumes from diesel and gasoline which otherwise will enter the spectrometer chamber damaging crystals, motors and detectors. In addition it significantly reduces the helium consumption and therefore the cost of operation, because helium flushing is only required for the small sample chamber, while the spectrometer chamber remains always in vacuum.

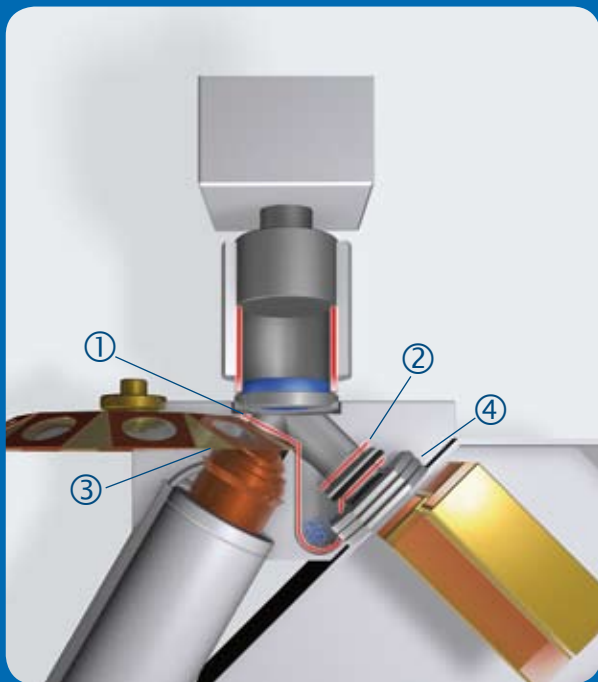

SampleCare for safe and reliable analysis of liquid samples

The SampleCare technology of the S8 TIGER 1 K constantly protects the X-ray tube and all goniometer components from damages due to oil spillage, which might lead to incorrect results or in the worst case to system stoppage. The S8 TIGER with SampleCare prevents this safely in 4 ways:

1. The contamination shield 1 protects the X-ray tube during loading.
2. The contamination shield 2 protects the goniometer during sample loading and helium flushing
3. The DuraBeryllium tube shield protects the head of the X-ray tube during measurement.
4. The vacuum seal with high transmission window separates the sample and goniometer chamber during measurement. It keeps the diesel fumes and oils from possible spillages out of the goniometer chamber, while this chamber has all the time vacuum.

If, by chance anything should have gone wrong and the sample leaks out, droplets are collected in the reservoir. System components are well protected, easy to access and can be cleaned with little effort.

Standard and Sample Preparation

Calibration according to ASTM D 2622-08 was performed with five standard samples prepared by using commercially available standards covering a concentration range from 0 – 50 ppm. The standards are traceable to the NIST reference sample SRM 1616 a – sulphur in kerosene.

Seven grams of the standard or sample were pipetted into a liquid cell prepared with a 3.6 µm Mylar film support shown in figure one. The samples were measured directly after preparation. Measurement

Measurements were performed on the S8 TIGER 1 K using the curved germanium crystal XS-GE-C, 0.46° collimator and 1 kW excitation with the settings 27 kV and 40 mA. The adjusted peak position of S Kα1 for the XS-GE-C crystal was set to a 2θ value of 110.746°, the background position was set at 112.746°. The measurement time was 100s for the peak and 30s for the background.

Results

The calibration curve was calculated from the intensity of the five standard samples by multiple regression. Calibration details are shown in table 1, the curve is shown in figure 2.

Table 1: Calibration Details for low sulphur in fuels.

Peak [° 2θ]	110.746°
Bkg [° 2θ]	112.746°
Cal. Offs. [ppm]	0.5
Cal. Dev. [ppm]	0.1
r ²	0.999987
LLD [ppm - 3σ, 100 s]	0.3

The detection limit is calculated according to

$$LLD = \frac{3}{m} \sqrt{\frac{I_b}{T_b}}$$

m = sensitivity of analyte in kcps/mass%

I_b = background intensity for analyte in kcps

T_b = counting time in seconds at the background angle

To test the precision of the method, one sample in the most important range below 10 ppm was measured twenty times. The results and the statistical parameters are shown in table 2 and figure 3.

ASTM D 2622-08 requires that the difference between two successive measurements must stay for 19 out of 20 cases below 0.57 for a level of 5.5 ppm. This test limit is calculated as follows:

$$\text{Repeatability (r)} = 0.1462 * \text{mean (c)}^{0.8015}$$



Figure 1: Quick, easy and simple sample preparation.

Table 2: Precision data for sulphur in fuels

Sample	S [ppm]	Difference [ppm]
1	5.42	
2	5.12	0.3
3	5.17	0.05
4	5.31	0.14
5	5.78	0.47
6	5.47	0.31
7	5.67	0.2
8	5.34	0.33
9	5.66	0.32
10	5.71	0.05
11	5.73	0.02
12	5.59	0.14
13	5.24	0.35
14	5.57	0.33
15	5.74	0.17
16	5.34	0.4
17	5.53	0.19
18	5.67	0.14
20	5.56	0.11
Mean value [ppm]	5.51	
Abs. Std. Dev. [ppm]	0.20	
Rel. Std. Dev. [%]	3.70	

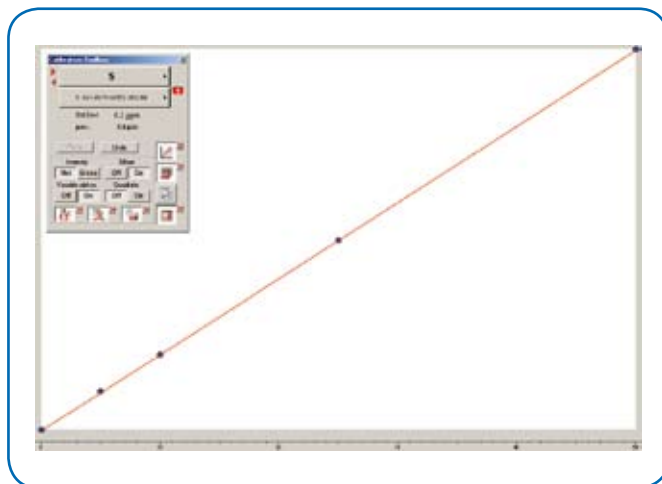

Figure 2: Calibration curve for ultra low sulphur in petroleum products covering a concentration range 0 – 50 ppm

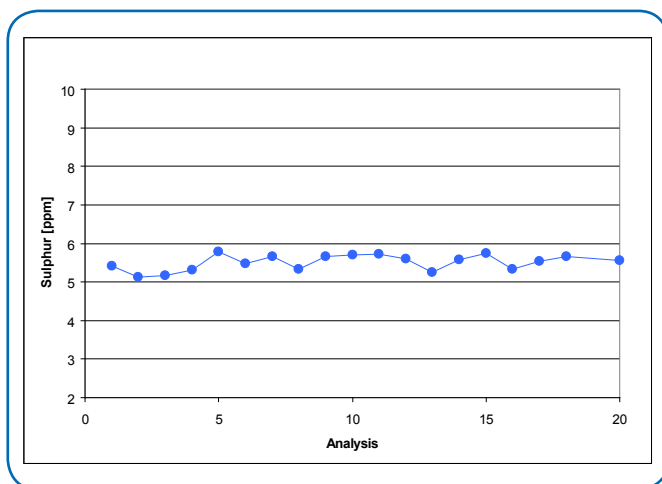

Fig. 3: ASTM D2622: Precision test at 5.5 ppm S samples

Conclusions

The analysis of low sulphur concentrations in automotive fuels according to ASTM D 2622-08 with the S8 TIGER 1 K is reliable, precise and accurate. The optimized excitation and the intensity optimized beam path with the curved germanium crystal XS-GE-C leads to an unmatched analytical performance. The precise and accurate determination of very low sulphur concentrations allows to drive the production of low sulphur automotive fuels in the most efficient way. Due to the unique vacuum seal and the SampleCare™ packages the S8 TIGER 1K is an indispensable tool for every refinery and testing lab providing safe and reliable analysis of liquid samples, highest instrument uptime and lowest cost of ownership.

Author

Bhaskar Bandyopadhyay, Bruker AXS AI Pvt Ltd, New Delhi
Dr. Kai Behrens, Bruker AXS GmbH, Karlsruhe, Germany

www.bruker.com

Bruker AXS GmbH

Karlsruhe, Germany
Phone +49 721 50997-0
Fax +49 721 50997-5654
info@bruker-axs.de

Bruker AXS Inc.

Madison, WI, USA
Phone +1 800 234-XRAY
Phone +1 608 276-3000
Fax +1 608 276-3006
info@bruker-axs.com